

Light for Appliances

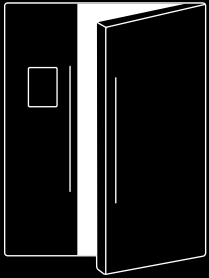

BJB///OEM-Line COLD



Lighting for refrigerators, freezers,
climate-cooled wine cabinets and wine coolers



Light and Automation
for Appliances

Index

Lighting for refrigerators, freezers,
climate-cooled wine cabinets and wine coolers

S. 4 77.116

Amber Light LED lamp
for storing wine

- Easy installation using swivel-screw fixing
- Minimal heat build-up
- The amber colour temperature protects the quality of wine
- Asymmetrical light distribution for optimum illumination of inside space
- High-quality aluminium profile



S. 6 77.103

Compact LED lamp for
refrigerators

- Flexible positioning thanks to small installation footprint
- Uniform light guide rod module that can be combined with adapters for individual cut-outs
- Small installation opening, minimum energy losses



S. 8 77.108

LED side/ceiling light for
refrigerators

- Light where it is needed: Specific directional light control
- Energy efficiency: Small installation opening minimises energy losses
- Easy installation through snap-in fixing



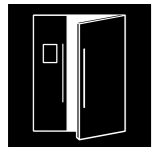

BJB///OEM-Line COLD

Amber Light LED lamp 77.116 for storing wine



LIGHT - JUST LIKE A WINE CELLAR

Temperature and air humidity play an important role when it comes to storing wine properly – but so does lighting. The 77.116 Amber Light lighting system from BJB was developed specifically to address this aspect. It is designed to reproduce the colour temperatures found in traditional wine cellars and creates a perfect spectrum for storing wine in climate-controlled cabinets and wine coolers. The system provides particular protection for white wines, which are kept in clear glass bottles.

Light emission characteristic

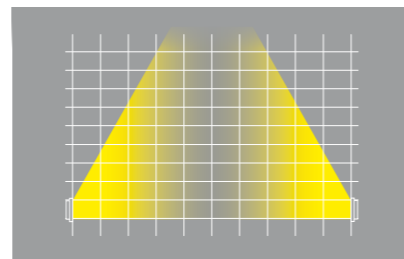

Asymmetrical illumination

ADDITIONAL FEATURES

LEDs

- The amber colour temperature protects the quality of wine
- Variable LED parameters (colour temperature, CRI, type, output)
- Energy efficiency: Possible leap forward into the next efficiency class

Thermal management

- Thermally optimised components
- Spring clamps ensure even contact pressure between the LED board and the heat sink
- Aluminium heat sink

Installation

- Easy installation using swivel-screw fixing
- Minimal protrusion into the interior

Design

- Variable length
- Linear lens made of plastic

Beam angle

- Asymmetrical (individually adjustable)

Protection class

- Class III due to operation with SELV power source

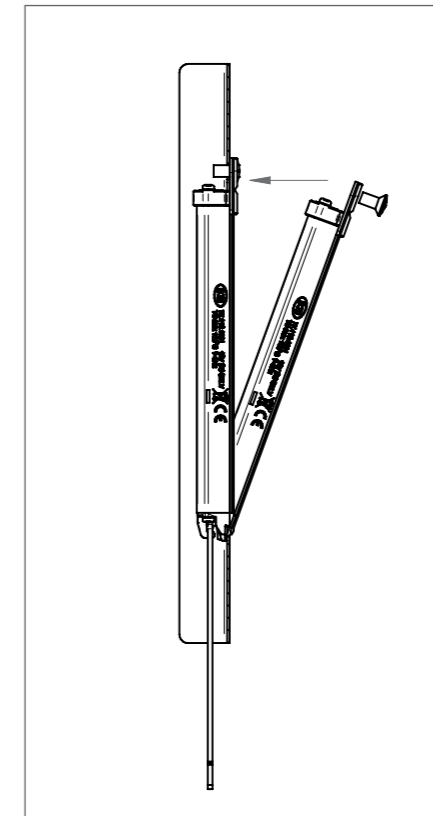

Swivel-screw fixing

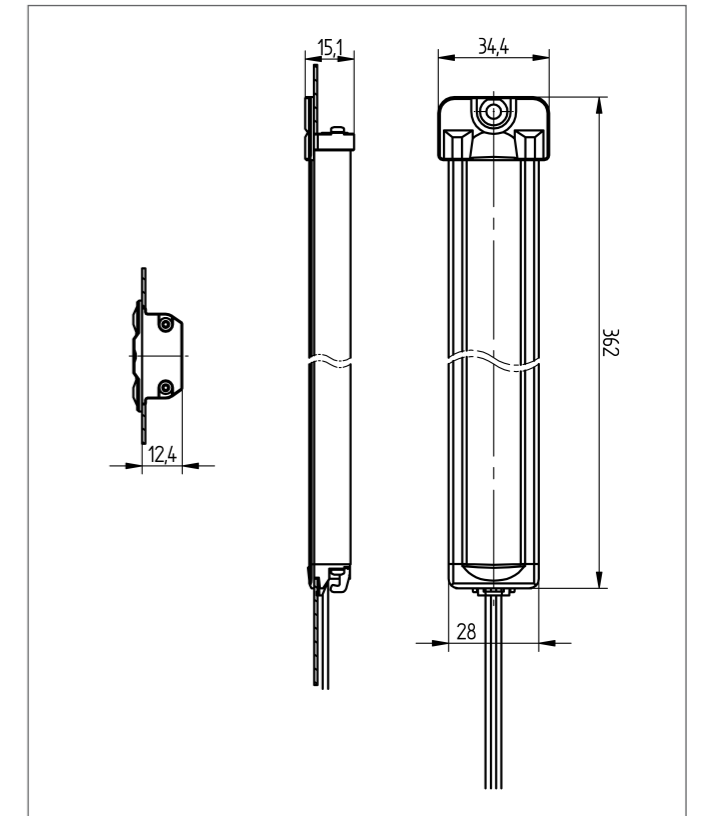

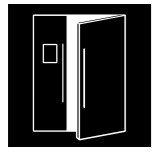

BJB///OEM-Line COLD

Compact 77.103 LED lamp for refrigerators



BRIGHT LIGHT WITH A SMALL FOOTPRINT

Conventional lighting solutions for refrigerators often require extra space for lampholders, light sources and covers. This LED lamp for refrigerators is different. It distributes light uniformly throughout the interior and is also much brighter than incandescent light bulbs. The core element is an LED light guide rod that can be combined with adapters to fit different cut-outs. This LED lamp combines improved light quality with increased efficiency and easy installation.

Light emission characteristic

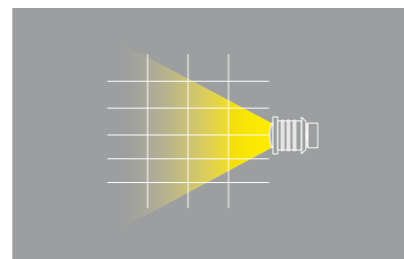

Uniform, bright illumination

ADDITIONAL FEATURES

LEDs

- Use of LEDs with various characteristics is possible
- Energy efficiency: Possible leap forward into the next efficiency class

Installation

- Minimal protrusion into the interior of the refrigerator
- Easy snap-in/clip-in installation

Further advantages

- Easy to clean
- Customer-specific adapters

Beam angle

- Symmetrical

Protection Class

- Class III due to operation with SELV power source

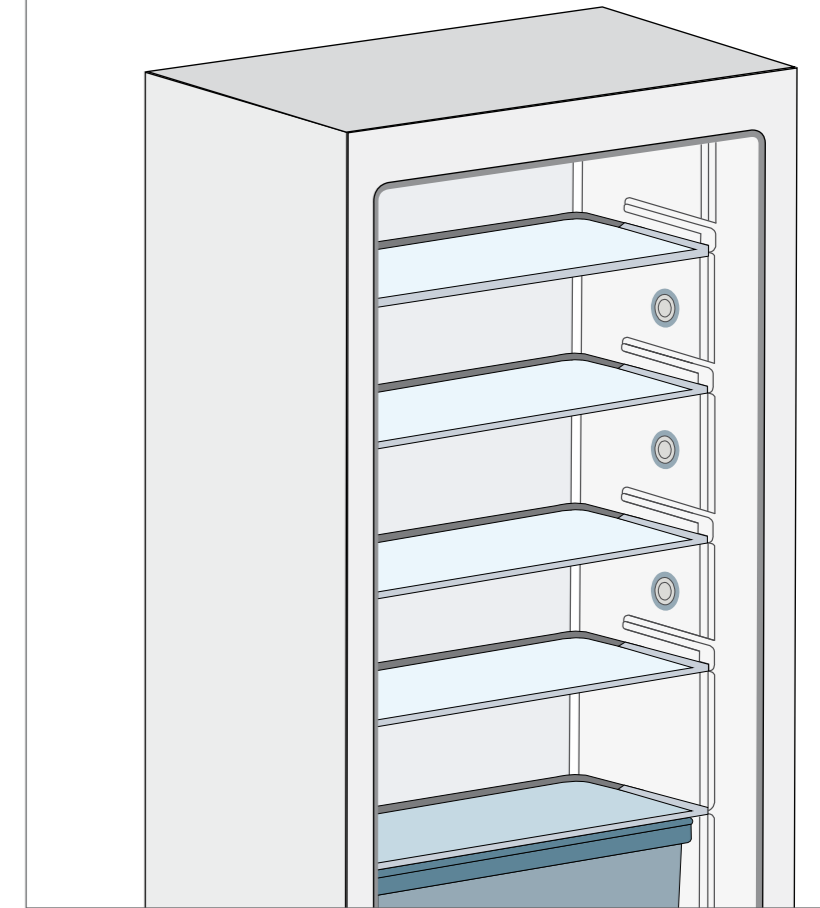

Example of application

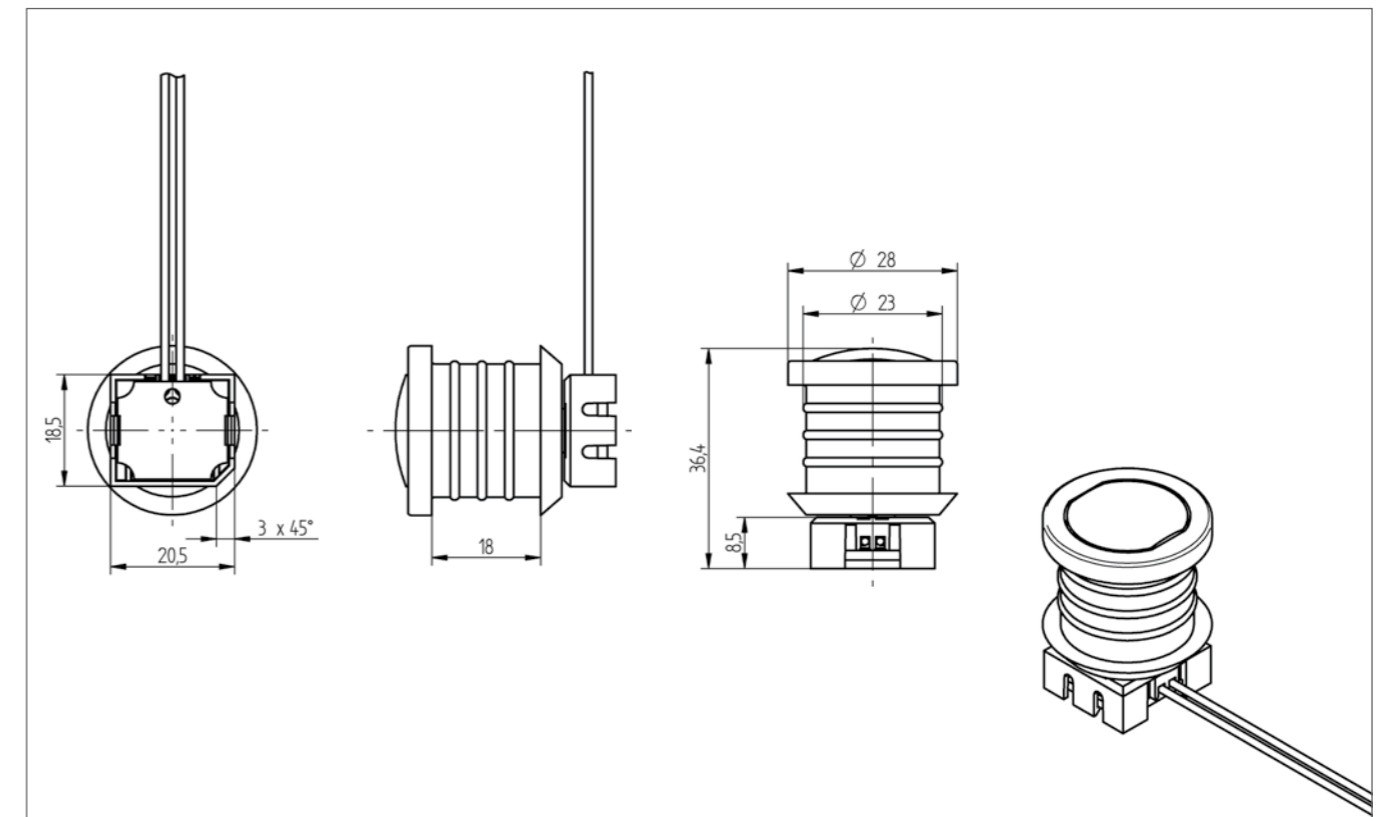

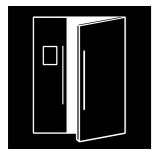

BJB///OEM-Line COLD

LED side/ceiling light 77.108 for refrigerators



GLARE-FREE FROM THE VERY BEGINNING

Thanks to a light-directing reflector, which provides an asymmetrical beam angle, this LED side and ceiling light considerably reduces glare in the refrigerator. In spite of its sophisticated light control technology, this product is also very suitable as an entry-level solution.

Light emission characteristic

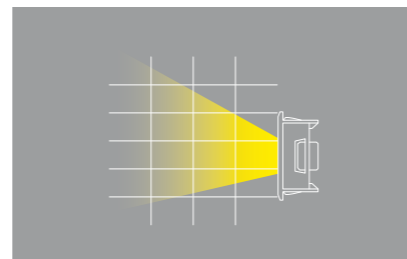

Light where it is needed: Specific directional light control

ADDITIONAL FEATURES

LEDs

- Variable LED parameters (colour temperature, CRI, power rating)
- Various lengths and types of cable possible
- Energy efficiency: Possibility to upgrade to a higher energy efficiency class

Installation

- Cover for foam sealing
- Coding ensures correct installation
- Snap-in fixing

Material

- High-quality plastic housing

Design

- Customer logo possible

Electronics

- Contact by means of edge connectors with or without connecting cable

Beam angle

- Asymmetrical

Protection class

- Class III due to operation with SELV power source

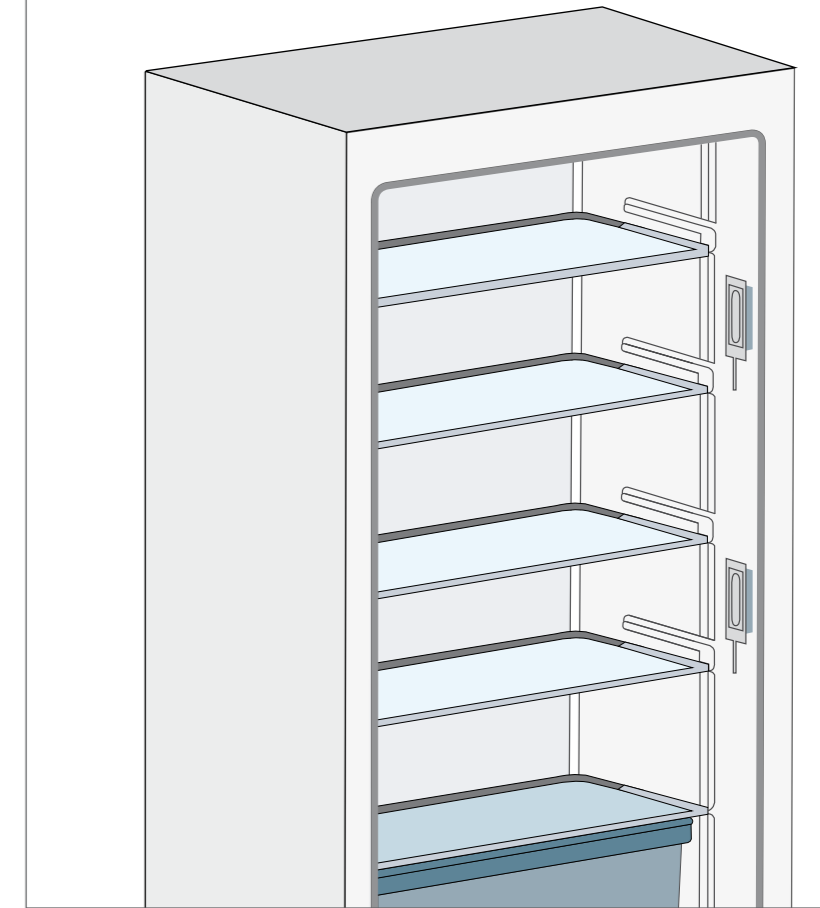

Example of application

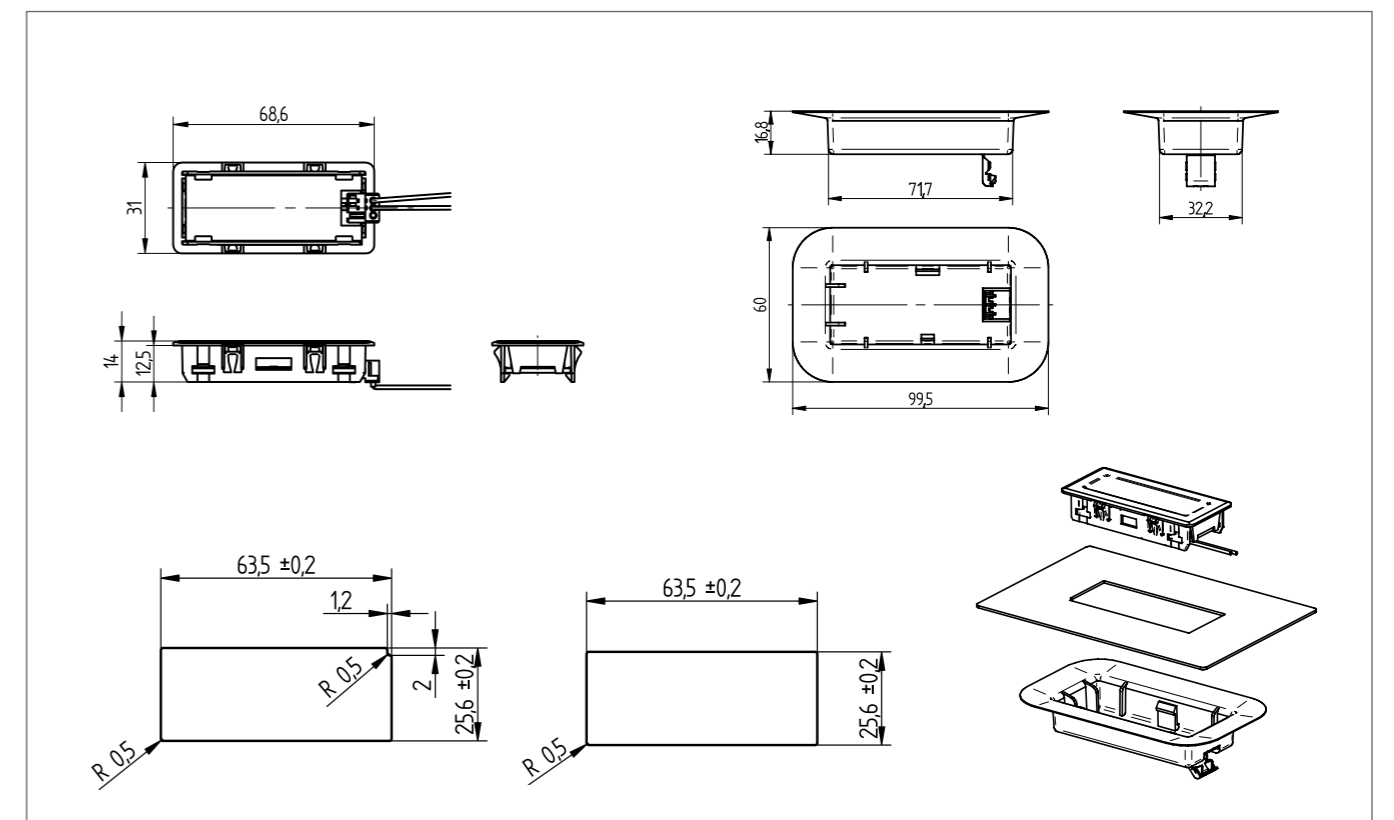





Light and Automation
for Appliances

BJB GmbH & Co. KG
Werler Straße 1
59755 Arnsberg
Germany
Telephone +49 29 32 9 82-0
Telefax +49 29 32 9 82-8201
info@bjb.com
www.bjb.com